



### MECHANICAL DATA

Shock (Non-Operating) . . . . .	10 G
Vibration (Non-Operating) . . . . .	10-150 cps—5 G
Mounting Position . . . . .	Any
Overall Dimensions . . . . .	5 $\frac{7}{8}$ x 3 $\frac{3}{16}$ x 5 $\frac{7}{8}$ Inches
Net Weight . . . . .	7.5 Lbs. approx.
Cooling . . . . .	Forced Air
Pressurization . . . . .	50 psi abs.
Output Coupling . . . . .	See Drawing

### ELECTRICAL DATA

#### HEATER CHARACTERISTICS

Heater Voltage—Preheat <sup>1</sup> . . . . .	5.0 $\pm$ 10% Volts
Heater Current at 5.0 Volts . . . . .	2.6 — 3.2 Amps
Minimum Preheat Time . . . . .	3 Minutes

#### RATINGS (Absolute Maximum)<sup>2</sup>

Heater Voltage . . . . .	6.0 Volts
Peak Current . . . . .	18 Amps
Peak Anode Voltage . . . . .	16 kv
Peak Power Input . . . . .	270 kw
Frequency Pulling at VSWR 1.5/1 . . . . .	30 mc
Anode Temperature . . . . .	130° C
Pulse Duration . . . . .	0.5 $\mu$ second
Duty Cycle . . . . .	0.0007
Minimum Pulse Voltage Rise Time . . . . .	0.08—0.1 $\mu$ second
VSWR . . . . .	1.5/1
R F Bandwidth . . . . .	15 mc

#### TYPICAL OPERATION

##### Oscillation 1

Pulse Recurrence Frequency . . . . .	4000 pps
Pulse Duration . . . . .	0.150 $\mu$ second
Peak Anode Voltage . . . . .	14 kv
Peak Anode Current . . . . .	15 Amps
Average Anode Current . . . . .	9 Ma
Useful Range of Average Current . . . . .	6-11 Ma
Average Power Output . . . . .	24 Watts
Input Capacitance . . . . .	8 $\mu$ f

Min.

#### NOTES:

1. Heater voltage must be reduced to zero after the application of high voltage.
2. The values specified are based on the "absolute system" and are not to be exceeded under any service conditions. The ratings are limiting values above which serviceability of any individual tube may be impaired. It does not necessarily follow that combinations of absolute maximum ratings can be attained simultaneously.

### QUICK REFERENCE DATA

The Sylvania Type 6551 is a medium power, pulsed fixed frequency (23800—24270 mc) magnetron.

The unit is supplied with magnet in place.

**SYLVANIA ELECTRIC  
PRODUCTS INC.**

**ELECTRONICS DIVISION  
WOBURN, MASS.**

*Prepared and Released By The  
TECHNICAL PUBLICATIONS SECTION  
EMPORIUM, PENNSYLVANIA*

JULY 1956

PAGE 1 OF 4

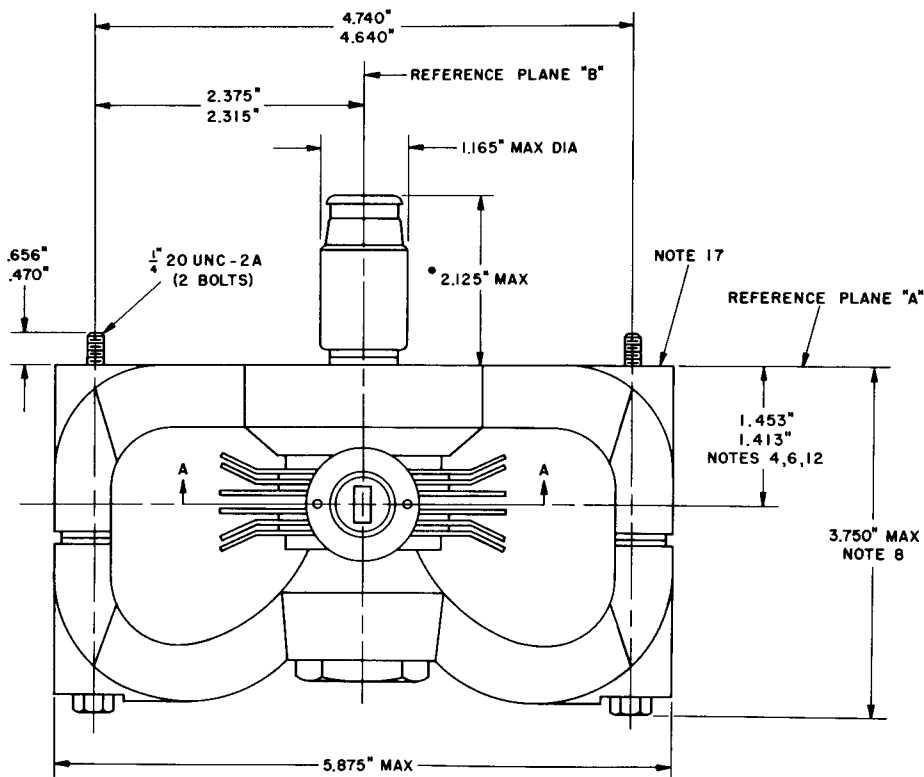
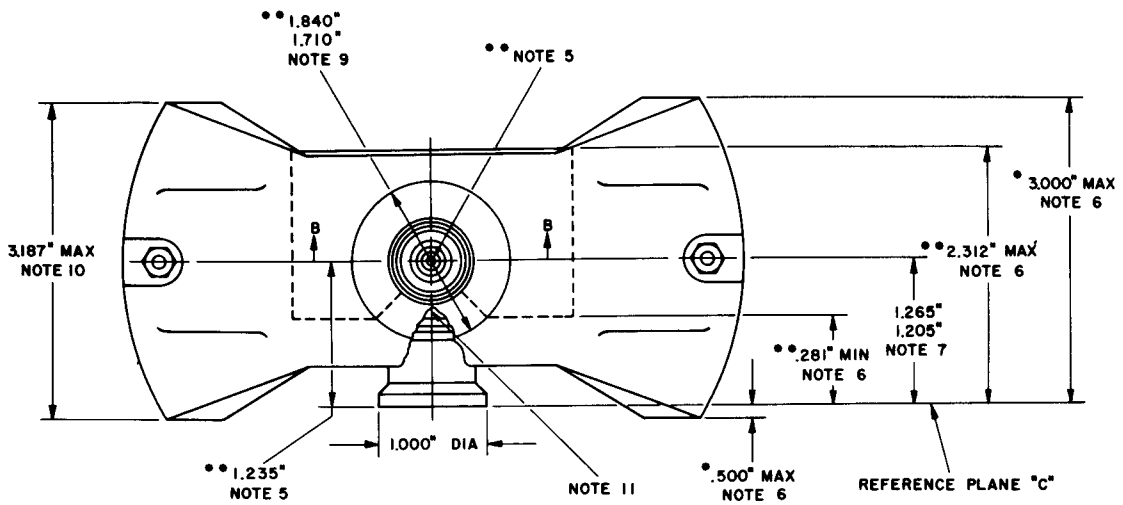

\*\*Qualification approval measurements.

\*Design test measurements.

Production—all other dimensions and notes.

FOR SECTION "A-A" & B-B  
SEE PAGE 3

All dim's in inches

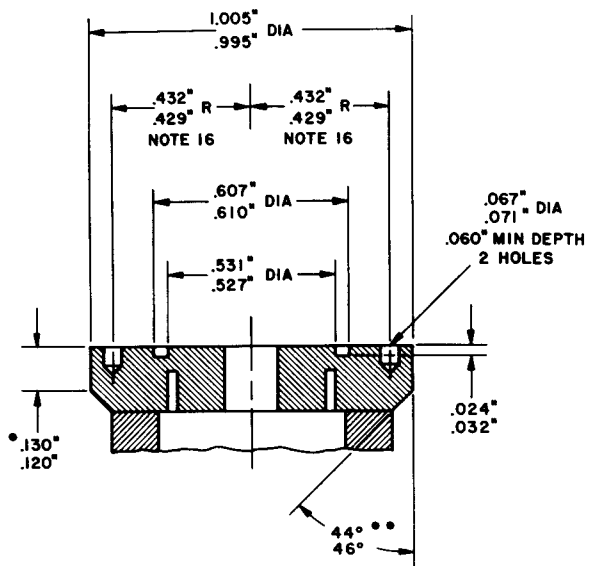

PARTIAL SECTION A-A

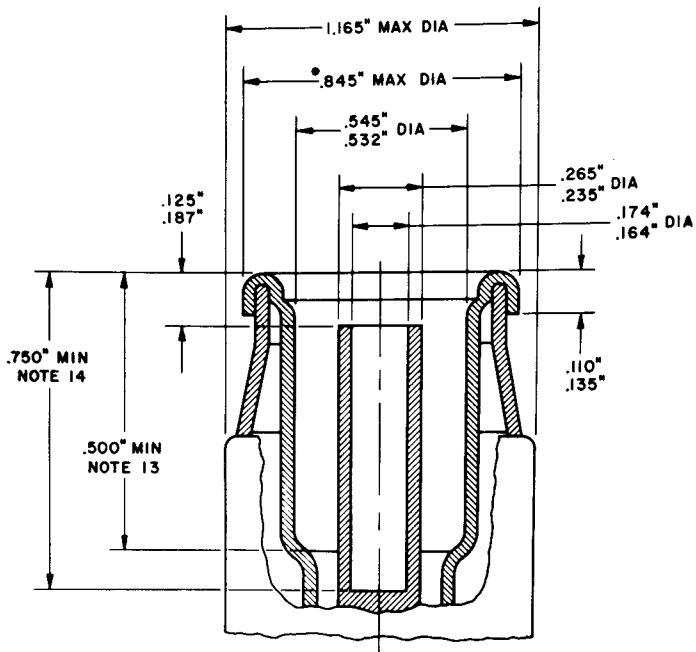

PARTIAL SECTION B-B

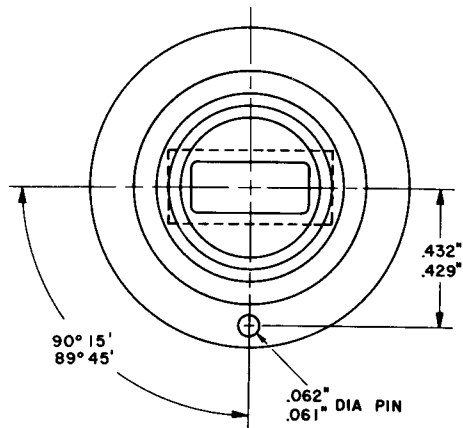
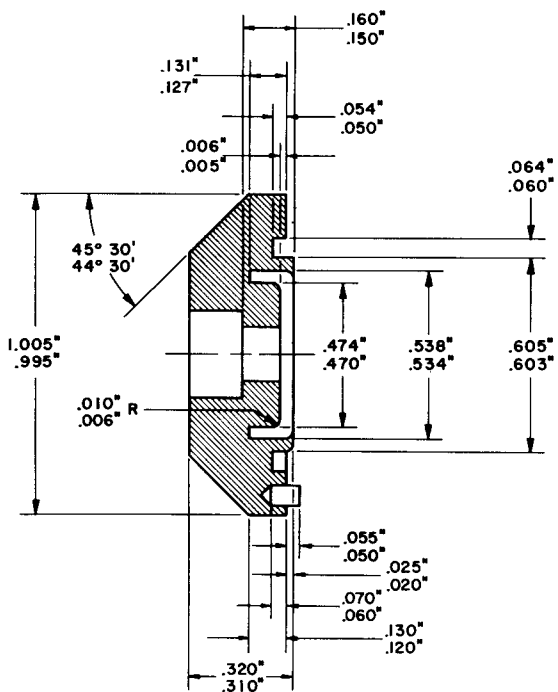

MATING CONNECTION FOR OUTPUT TERMINAL

**DRAWING NOTES:**

1. Ref. plane "A" is defined as a plane passing through the finished surface of the magnet as shown.
2. Ref. plane "B" is defined as a plane passing through the center of the output and perpendicular to ref. plane A.
3. Ref. plane "C" is defined as a plane perpendicular to planes "A" and "B" at the face of the output.
4. This dimension refers to centerline of tube.
5. Center of cathode bushing may vary from true location by .125 (See Note 7).
6. Includes angular as well as lateral deviations.
7. This dimension applies to location of mounting bolts with respect to ref. plane C.
8. This dimension applies either to head of magnet bolt or top of exhaust cap or magnet coating.
9. Applies to flat on top of magnet.
10. Refers to size of coated magnet only.
11. Temperature is measured at this point.
12. Centerline of drilled holes in output flange may vary from true location by .007.
13. This dimension refers to .532-.545 dia.
14. This dimension refers to .164-.174 dia.
15. Alignment of the electric vector shall be perpendicular to Ref. plane "B".
16. Refers to centerline of .607-.610 dia.
17. This surface to be flat within .010.